

## SPECIFICATIONS



# MAT20MN TOP-LOAD WASHER



### DEEP-WATER WASH SYSTEM

- Provides optimal wash performance with deep-water wash and rinse cycle options and vigorous cleaning action.
- Traditional flex-vane agitator provides four distinct wash profiles—from aggressive to gentle—designed to pull clothes from the top to the bottom of the wash basket.
- PowerWash® cycle provides more agitation, hotter water, and an extra rinse for the dirtiest loads.



### SIMPLE, EASY-TO-USE CONTROLS

- Mechanical controls provide a simple user interface with robust, easy-to-use knobs.



### POWERFUL DRIVE SYSTEM

- Enhanced design of the triple-lip seal and stainless-steel shaft, in addition to the premium bearings, delivers reliability and consistency.
- Powerful 1/2-HP PSC motor and quad-gear transmission create an efficient wash for every load.



### HEAVY-DUTY CABINET

- Possesses the strength needed for high-demand commercial environments.
- Sturdy front panel, side panels, and easy-access base are all manufactured from high-grade, extra-strength galvanized steel.



REMOVABLE FRONT PANEL



PREMIUM PORCELAIN ENAMEL TOP & LID



EASY-ACCESS STEEL BASE

# SPECIFICATIONS

# MAT20MN TOP-LOAD WASHER



## MAYTAG® COMMERCIAL TOP-LOAD WASHER MECHANICAL CONTROLS, NON-COIN

WASHER SPECIFICATIONS	
<b>MODEL</b>	MAT20MNAWW / DOMESTIC
<b>MOTOR SIZE – HP (KW)</b>	1/2 (.37)
<b>MODIFIED ENERGY FACTOR (MEF<sub>J2</sub>)*</b>	1.6
<b>INTEGRATED WATER FACTOR (IWF)*</b>	7.8
<b>APPROXIMATE WATER USAGE</b>	
Average Total Water Usage Per Cycle – Gallons (liters)*	25.6 (96.9)
Average Hot Water Usage, Warm Water Cycle – Gallons (liters)	0.53 (2)
Average Hot Water Usage, Hot Water Cycle – Gallons (liters)	6.51 (24.6)
<b>EXTRACT SPEED – MAX G-FORCE / MAX RPM</b>	144 / 700
<b>CAPACITY</b>	
Cylinder Volume – cu. ft. (liters)	3.27 (92.6)
Cylinder Diameter – in. (mm)	20.8 (528)
Cylinder Depth – in. (mm)	23.8 (605)
<b>DIMENSIONS</b>	
Width – in. (mm)	27 (686)
Depth – in. (mm)	26 (660)
Height – in. (mm)	42 1/2 (1,080)
Lid Opening – in. (mm)	17 (432)
<b>CRATED DIMENSIONS</b>	
Width – in. (mm)	29 (737)
Depth – in. (mm)	27.5 (699)
Height – in. (mm)	49 (1,255)
<b>APPROXIMATE WEIGHT</b>	
Uncrated – lbs. (kg)	145 (65.8)
Crated – lbs. (kg)	163 (73.9)
<b>ELECTRICAL REQUIREMENTS</b>	
Electrical Rating – voltage / Hz	120 / 60
Breaker / Fuse – amps	15
<b>WATER INLET / HOSE</b>	
Operating Pressure PSI (bar)	20 – 100 (1 – 8)
Inlet Hose Length – ft. (m)	6 (1.8)
Drain Hose Length – ft. (m)	4.2 (1.3)
<b>WARRANTY</b>	
	5-Year Limited

Dimensions are for planning purposes only. See specific instructions for proper installation. Because of continuous product improvement, Maytag reserves the right to change specifications without notice.

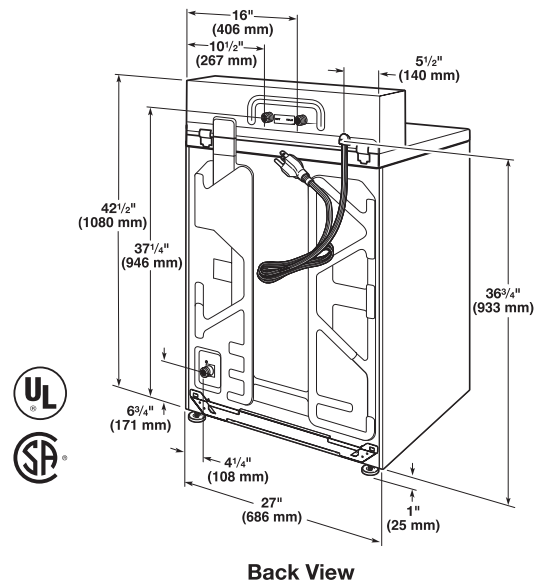
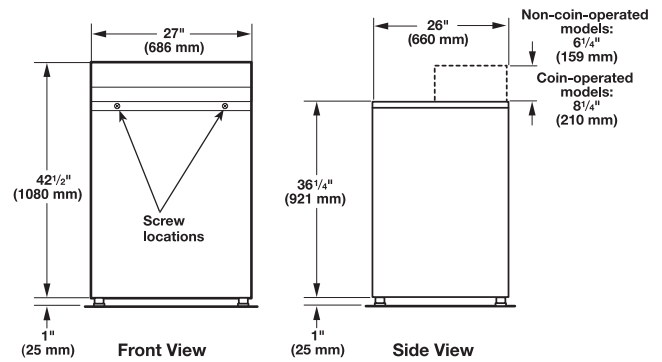

\*Based on 2018 United States DOE J2 Testing with factory preset cycles.



**5-YEAR LIMITED WARRANTY  
ALL PARTS COVERED**

See [maytagcommerciallaundry.com](http://maytagcommerciallaundry.com) for complete warranty details.